

Ordering Code: **EP-42M-X-Y-Z-95**

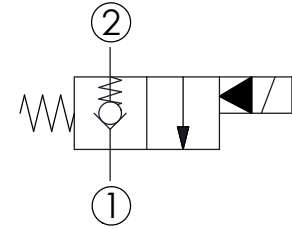
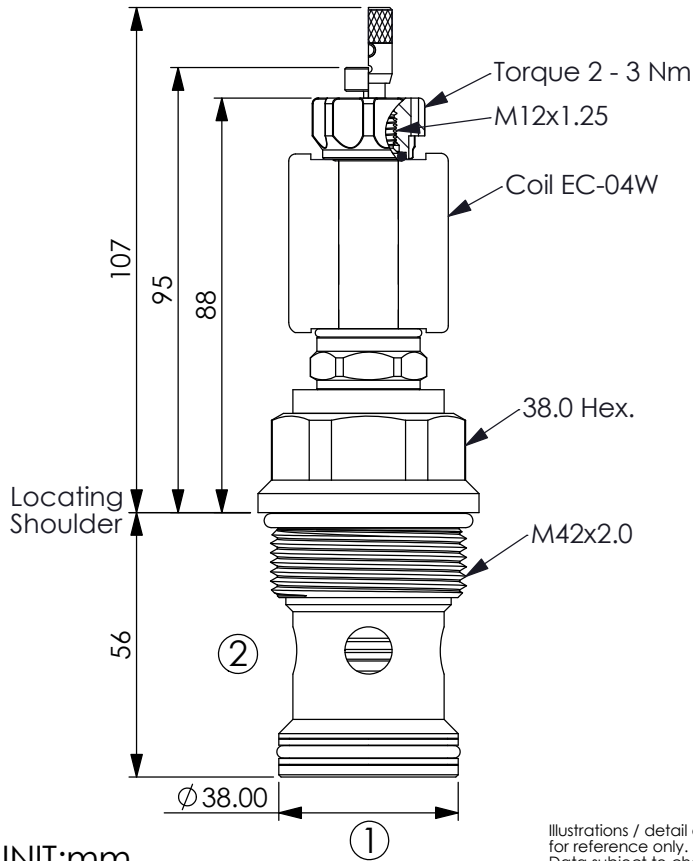

### TECHNICAL DATA

Max. Operating pressure:	350 bar
Rated flow:	300 l/min
Cavity-Tooling:	42M-2
Installation torque:	110 - 130 Nm
Weight:	0.674 (Z=N) kg

Internal Leakage Approximately:  
0.15 cc/minute  
(3 drops/minute) max. at 350 bar

Hydraulic Fluid Viscosity · Cleanliness · Temperature Level:  
Please refer WINNER technical information.  
( T.101.101.E HYDRAULIC FLUID (A) VISCOSITY )  
( T.101.102.E HYDRAULIC FLUID (B) CLEANLINESS )  
( T.101.103.E HYDRAULIC FLUID (C) TEMPERATURE )

Minimum Voltage Required:  
90 % of nominal

Coils must be ordered separately

Mounting Position: unrestricted

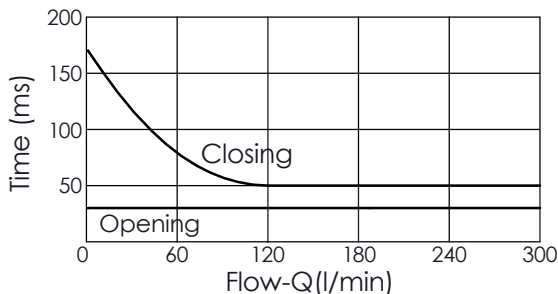
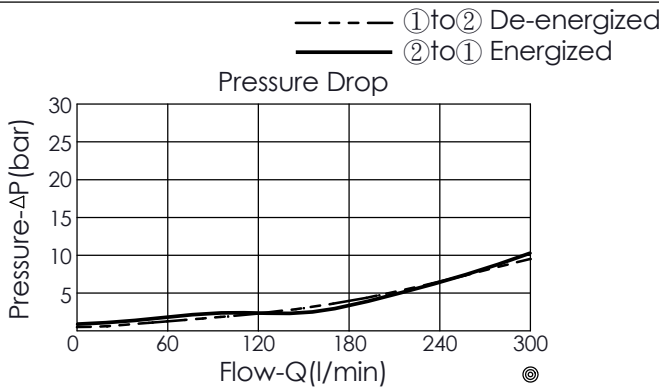

The performance curve or data is only for reference, as customers' using condition, pressure, flow, hydraulic fluid viscosity, cleanliness, temperature and so on are different, the curve or data will be different.

X	STRUCTURE	
2A	2 Ports · 20 Watt. Coil φ 12.7 mm tube	

Z	OPTIONS	
N	Non-adjustable	
P	Push Style Manual Override	
T	Push and Twist Style Manual Override (For emergency or test use only. Please keep at the normal operational position after turning counterclockwise.) (A larger force is required for downward push during high-pressure operations, please contact Winner's sales department.)	

Y	OPERATION	
01	Normally-Closed No Reverse Flow Energized	