

Ordering Code: **EP-08W-X-Y-Z-05**

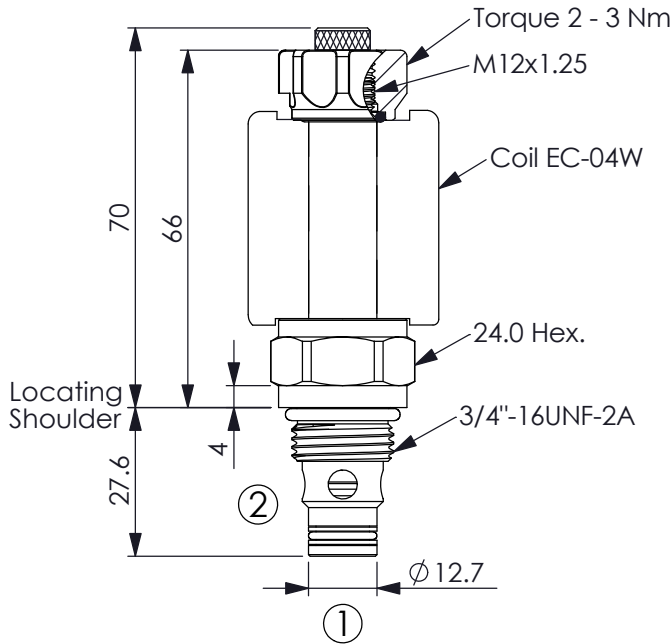

UNIT:mm

Illustrations / detail are for reference only. Data subject to change.

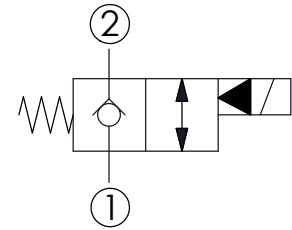

TECHNICAL DATA

Max.Operating pressure:	350 bar
Rated flow:	40 l/min
Cavity-Tooling:	08W-2
Installation torque:	39 - 51 Nm
Weight:	0.125 (Z=N) kg

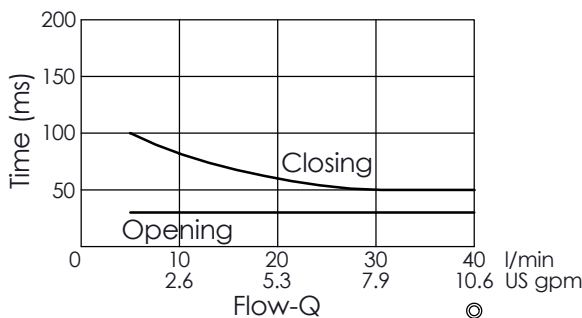
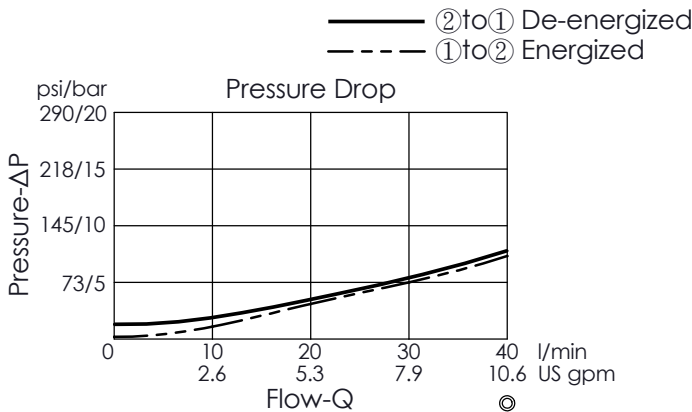

The performance curve or data is only for reference, as customers' using condition, pressure, flow, hydraulic fluid viscosity, cleanliness, temperature and so on are different, the curve or data will be different.

Internal Leakage Approximately:
0.15 cc/minute
(3 drops/minute) max. at 350 bar

Hydraulic Fluid Viscosity · Cleanliness · Temperature Level:
Please refer WINNER technical information.
(T.101.101.E HYDRAULIC FLUID (A) VISCOSITY)
(T.101.102.E HYDRAULIC FLUID (B) CLEANLINESS)
(T.101.103.E HYDRAULIC FLUID (C) TEMPERATURE)

Minimum Voltage Required:
90 % of nominal

Coils must be ordered separately

Mounting Position: unrestricted

X	STRUCTURE	
2A	2 Ports · 20 Watt. Coil Ø 12.7 mm tube	

Y	OPERATION	
03	Normally-Closed, Reverse Flow Energized, Nose-in, Side-out Operation	

Z	OPTIONS	
N	Non-adjustable	
M	Screw-out Knob Style	