

Ordering Code: **EP-22M-X-Y-Z-05**

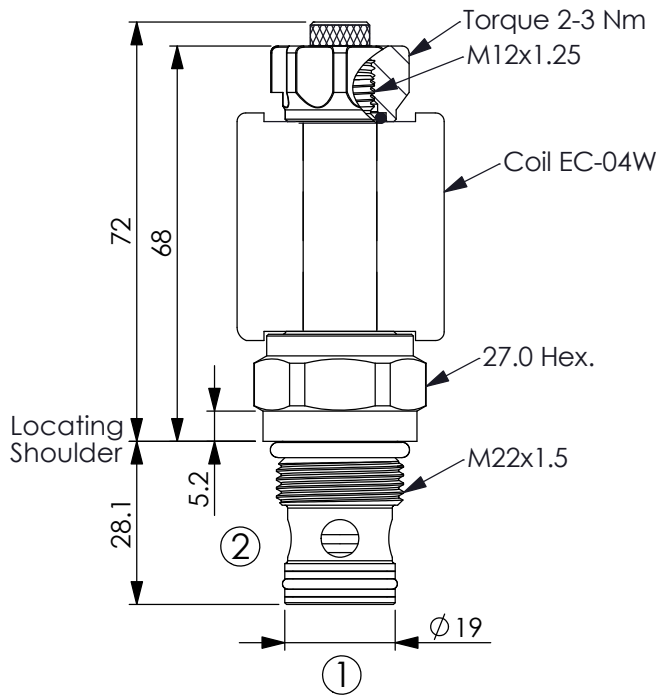

UNIT:mm

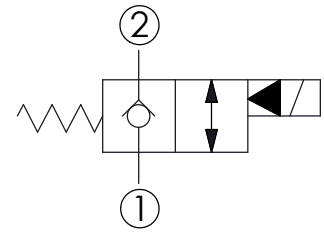

TECHNICAL DATA

Max.Operating pressure: 350 bar

Rated flow: 70 l/min

Cavity-Tooling: 22M-2

Installation torque: 44-56 Nm

Weight: 0.16 (Z=N) kg

Fluids-Temperatures: -40 to 120 °C

Internal Leakage Approximately:
0.15 cc/minute
(3 drops/minute) max. at 350 bar

Hydraulic Fluid Cleanliness Level:
Please refer WINNER technical information.
(T.101.102.E HYDRAULIC FLUID (B)CLEANLISS)

Minimum Voltage Required:
90 % of nominal

Coils must be ordered separately

Mounting Position: unrestricted

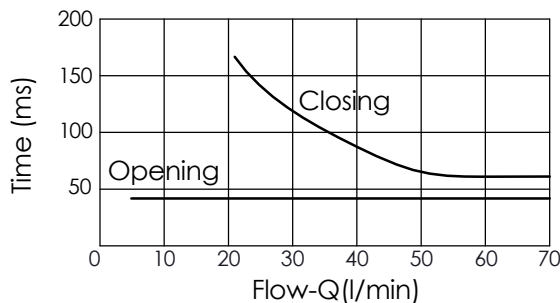
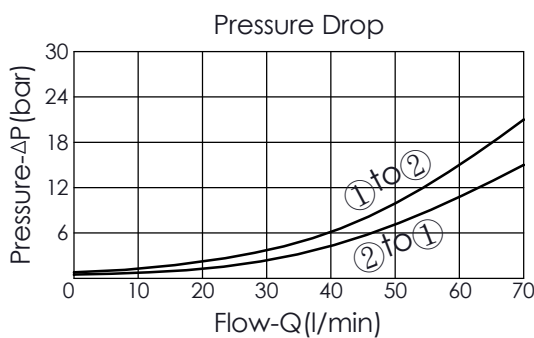

Y	OPERATION
03	Normally-Closed,Reverse Flow Energized,Nose-in,Side-out Operation

X	STRUCTURE
2A	2 Ports · 20 Watt. Coil ∅ 12.7 mm tube

Z	OPTIONS
N	Non-adjustable 
M	Screw-out Knob Style 