

Ordering Code: **EP-35MV-X-Y-Z-05**

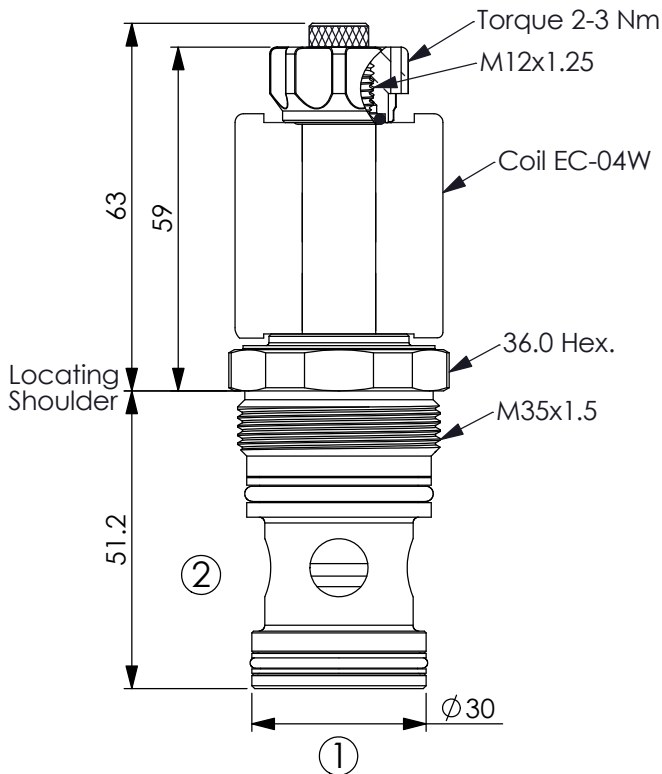

UNIT:mm

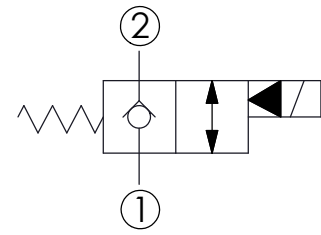

### TECHNICAL DATA

Max.Operating pressure: 350 bar

Rated flow: 150 l/min

Cavity-Tooling: 35MV-2

Installation torque: 80-100 Nm

Weight: 0.34 (Z=N) kg

Fluids-Temperatures: -40 to 120 °C

Internal Leakage Approximately:  
0.15 cc/minute  
(3 drops/minute) max. at 350 bar

Hydraulic Fluid Cleanliness Level:  
Please refer WINNER technical information.  
( T.101.102.E HYDRAULIC FLUID (B)CLEANLINESS )

Minimum Voltage Required:  
90 % of nominal

Coils must be ordered separately

Mounting Position: unrestricted

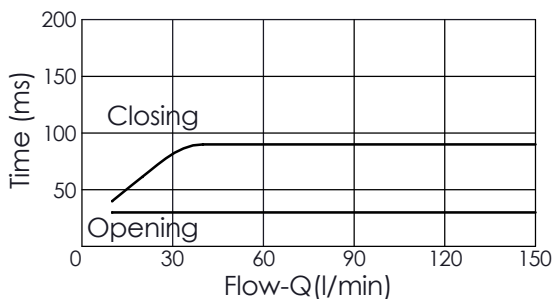
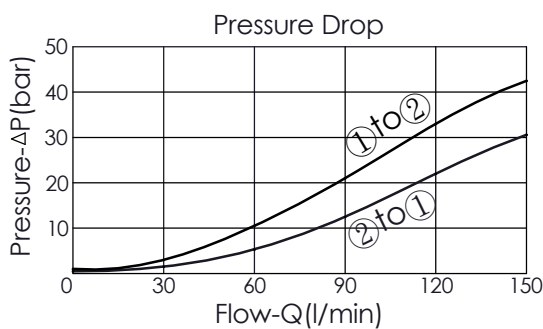

X	STRUCTURE
2A	2 Ports - 20 Watt. Coil $\phi$ 12.7 mm tube

Y	OPERATION
03	Normally-Closed,Reverse Flow Energized,Nose-in,Side-out Operation

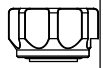
Z	OPTIONS
N	Non-adjustable 
M	Screw-out Knob Style 