

Ordering Code: **EP-13A-X-Y-Z-05**

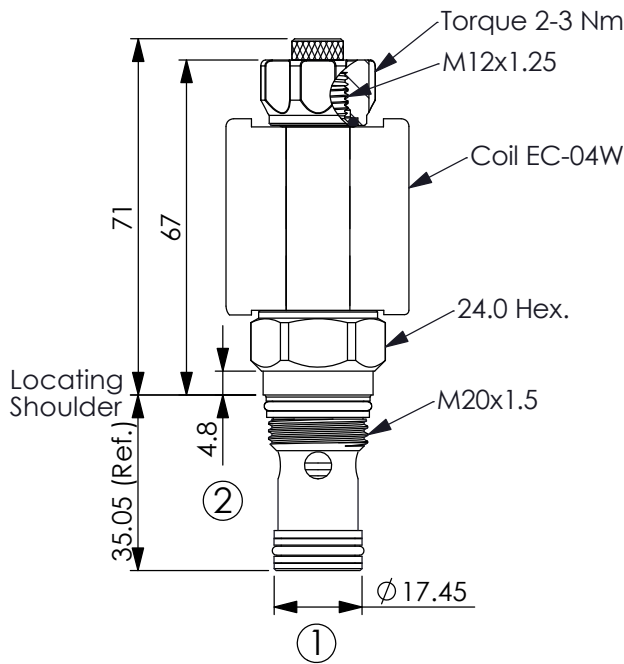

UNIT:mm

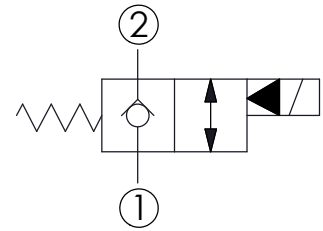
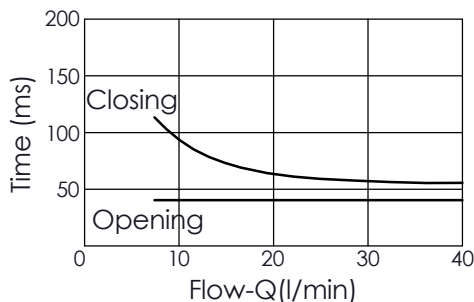
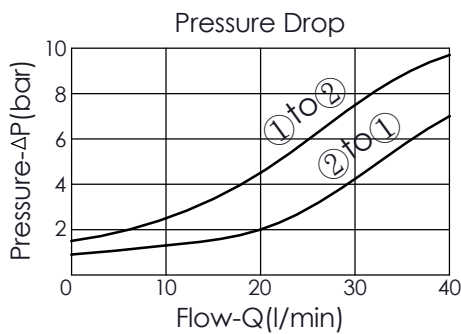

TECHNICAL DATA

Max. Operating pressure: 350 bar

Rated flow: 40 l/min

Cavity-Tooling: 13A-2

Installation torque: 39-51 Nm

Weight: 0.14 (Z=N) kg

Fluids-Temperatures: -40 to 120 °C

Internal Leakage Approximately:
0.15 cc/minute
(3 drops/minute) max. at 350 bar

Hydraulic Fluid Cleanliness Level:
Please refer WINNER technical information.
(T.101.102.E HYDRAULIC FLUID (B) CLEANLINESS)

Minimum Voltage Required:
90 % of nominal

Coils must be ordered separately

Mounting Position: unrestricted

X	STRUCTURE	
2A	2 Ports - 20 Watt. Coil	
	∅ 12.7 mm tube	

Y	OPERATION	
03	Normally-Closed, Reverse Flow Energized, Nose-in, Side-out Operation	

Z	OPTIONS	
N	Non-adjustable	
M	Screw-out Knob Style	