

SOLENOID OPERATED VALVE (Pilot Operated) (Poppet 2-Way Normally-Closed Cartridge Style With Extra Spring)

Ordering Code: **EP-17E-X-Y-Z-85**

This design allows faster response times with very small flow or even virtually zero flow.

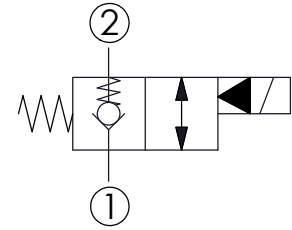
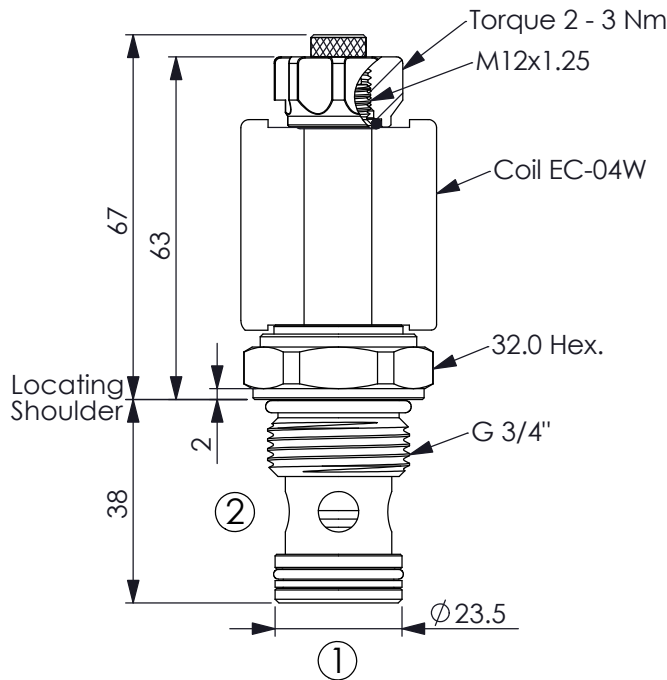

UNIT:mm

Illustrations / detail are for reference only. Data subject to change.

TECHNICAL DATA

Max.Operating pressure:	350	bar
Rated flow:	70	l/min
Cavity-Tooling:	17E-2	
Installation torque:	54 - 66	Nm
Weight:	0.221 (Z=M)	kg

Internal Leakage Approximately:
0.15 cc/minute
(3 drops/minute) max. at 350 bar

Hydraulic Fluid Viscosity · Cleanliness · Temperature Level:
Please refer WINNER technical information.
(T.101.101.E HYDRAULIC FLUID (A) VISCOSITY)
(T.101.102.E HYDRAULIC FLUID (B) CLEANLINESS)
(T.101.103.E HYDRAULIC FLUID (C) TEMPERATURE)

Minimum Voltage Required:
90 % of nominal

Coils must be ordered separately

Mounting Position: unrestricted

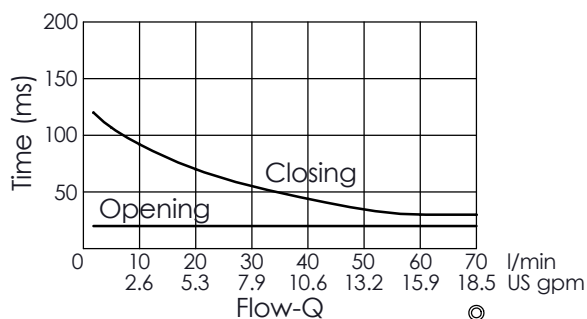
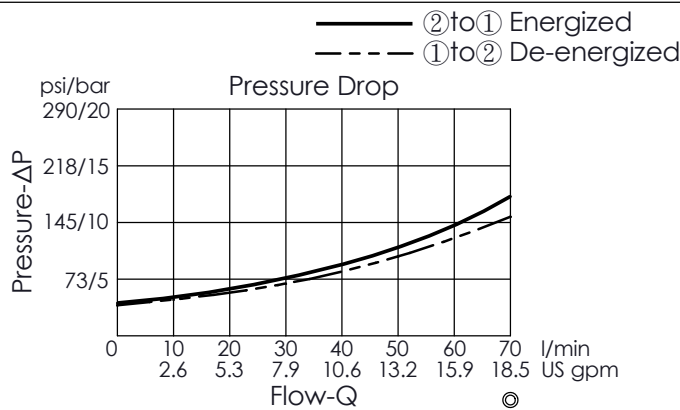

The performance curve or data is only for reference, as customers' using condition, pressure, flow, hydraulic fluid viscosity, cleanliness, temperature and so on are different, the curve or data will be different.

X	STRUCTURE	
2A	2 Ports · 20 Watt. Coil	
	∅ 12.7 mm tube	

Z	OPTIONS	
N	Non-adjustable	
M	Screw-out Knob Style	

Y	OPERATION	
05	Normally-Closed Reverse Flow Energized	