

Ordering Code: **EP-16W-X-Y-Z-05**

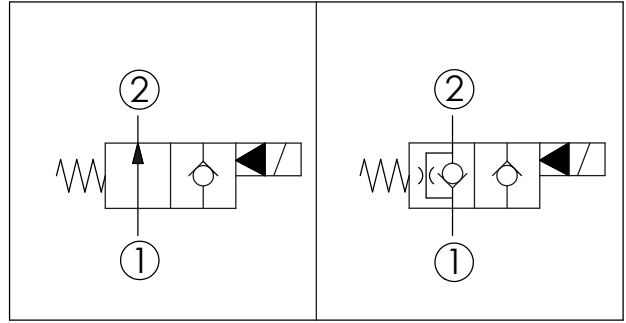
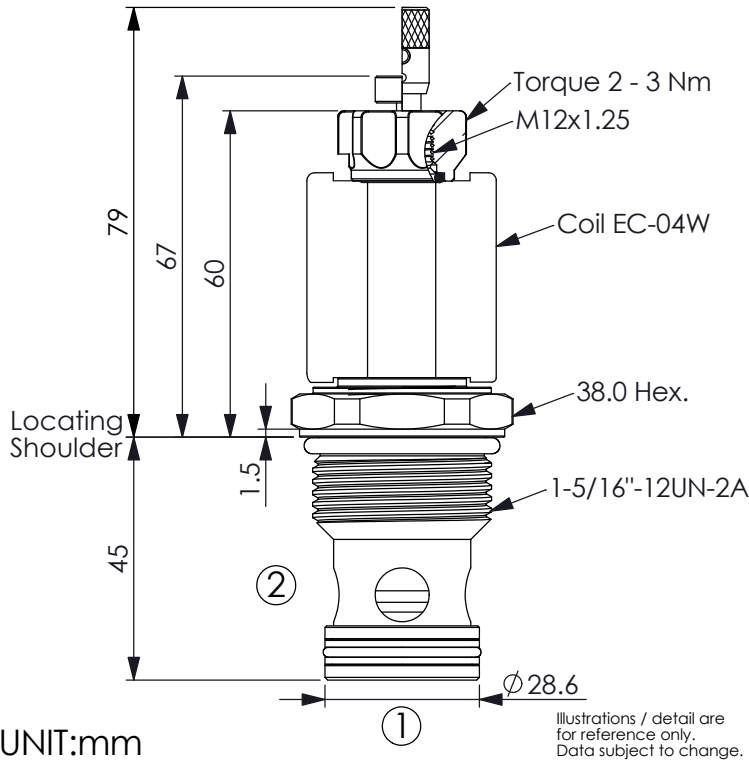

### TECHNICAL DATA

Max. Operating pressure: 350 bar

Rated flow: 150 l/min

Cavity-Tooling: 16W-2

Installation torque: 80 - 100 Nm

Weight: 0.329 (Z=T) kg

Internal Leakage Approximately:  
0.15 cc/minute  
(3 drops/minute) max. at 350 bar

Hydraulic Fluid Viscosity · Cleanliness · Temperature Level:  
Please refer WINNER technical information.  
( T.101.101.E HYDRAULIC FLUID (A) VISCOSITY )  
( T.101.102.E HYDRAULIC FLUID (B) CLEANLINESS )  
( T.101.103.E HYDRAULIC FLUID (C) TEMPERATURE )

Minimum Voltage Required:  
90 % of nominal

Coils must be ordered separately

Mounting Position: unrestricted

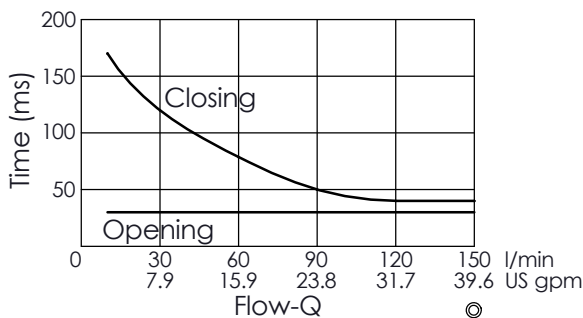
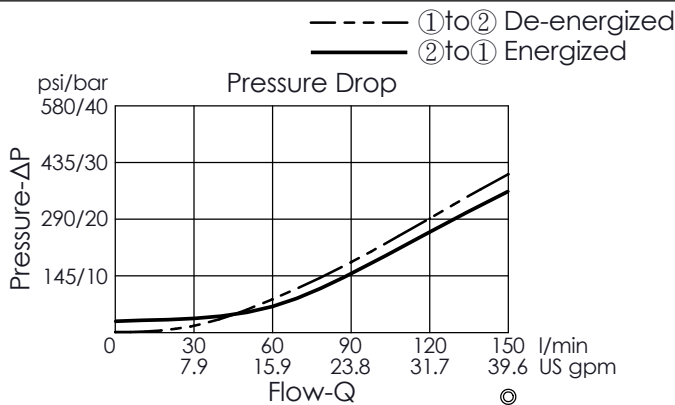

The performance curve or data is only for reference, as customers' using condition, pressure, flow, hydraulic fluid viscosity, cleanliness, temperature and so on are different, the curve or data will be different.

### Y OPERATION

**10** Normally-Open, No Reverse Flow  
De-energized, Nose-in, Side-out Operation

In de-energized condition, this valve is allowed flow from port ① to port ② but it's difficult to pass that flow from port ② to port ①.  
This valve is similar to check valve when energized. Allow free flow from port ② to port ① and block flow from port ① to port ②.  
If you need bi-directional flow, please refer Y=04.

### X STRUCTURE

**2A** 2 Ports · 20 Watt. Coil  
Ø 12.7 mm tube

### Z OPTIONS

**N** Non-adjustable

**P** Push Style Manual Override

**T** Push and Twist Style Manual Override  
(For emergency or test use only. Please keep at the normal operational position after turning counterclockwise.)  
(A larger force is required for downward push during high-pressure operations, please contact Winner's sales department.)