

SOLENOID OPERATED VALVE (Pilot Operated) (Poppet 2-Way Normally-Closed Cartridge Style With Extra Spring)

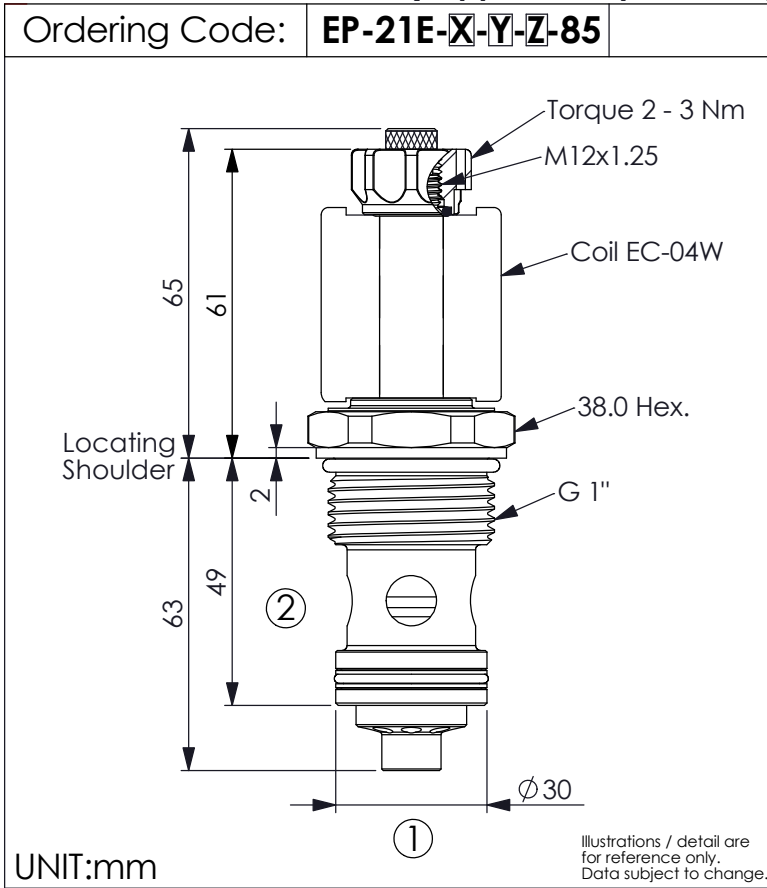

This design allows faster response times with very small flow or even virtually zero flow.

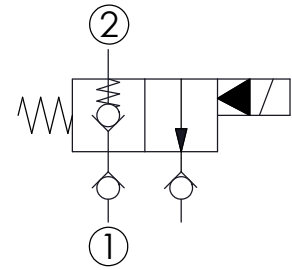

TECHNICAL DATA

Max. Operating pressure:	350 bar
Rated flow:	150 l/min
Cavity-Tooling:	21E-2
Installation torque:	80 - 100 Nm
Weight:	0.355 (Z=N) kg

Internal Leakage Approximately:
0.15 cc/minute
(3 drops/minute) max. at 350 bar

Hydraulic Fluid Viscosity · Cleanliness · Temperature Level:
Please refer WINNER technical information.
(T.101.101.E HYDRAULIC FLUID (A) VISCOSITY)
(T.101.102.E HYDRAULIC FLUID (B) CLEANLINESS)
(T.101.103.E HYDRAULIC FLUID (C) TEMPERATURE)

Minimum Voltage Required:
90 % of nominal

Coils must be ordered separately

Mounting Position: unrestricted

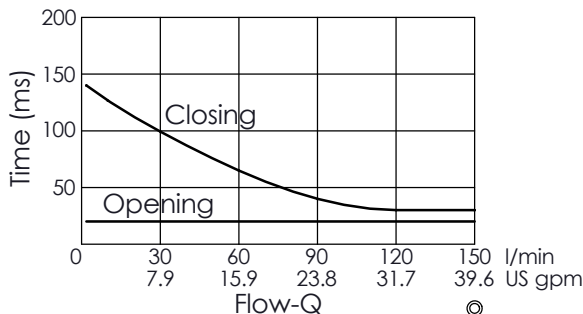
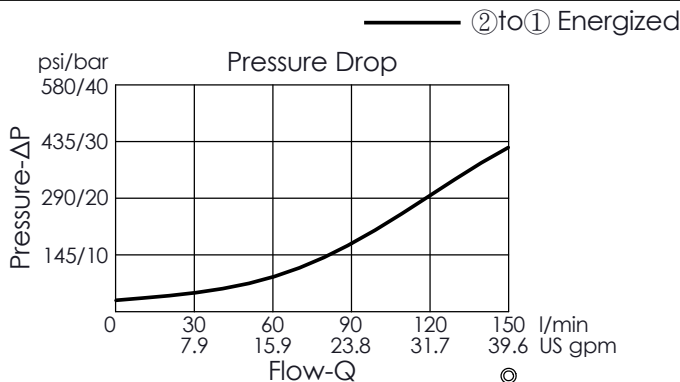

The performance curve or data is only for reference, as customers' using condition, pressure, flow, hydraulic fluid viscosity, cleanliness, temperature and so on are different, the curve or data will be different.

X	STRUCTURE
2A	2 Ports · 20 Watt. Coil Ø 12.7 mm tube

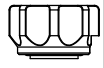
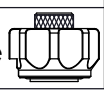
Z	OPTIONS
N	Non-adjustable 
M	Screw-out Knob Style 

Y	OPERATION
11	Normally-Closed Internal Reverse Check Valve