

Ordering Code: **EP-12W-X-Y-Z-85**

This design allows faster response times with very small flow or even virtually zero flow.

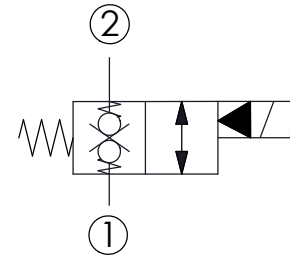
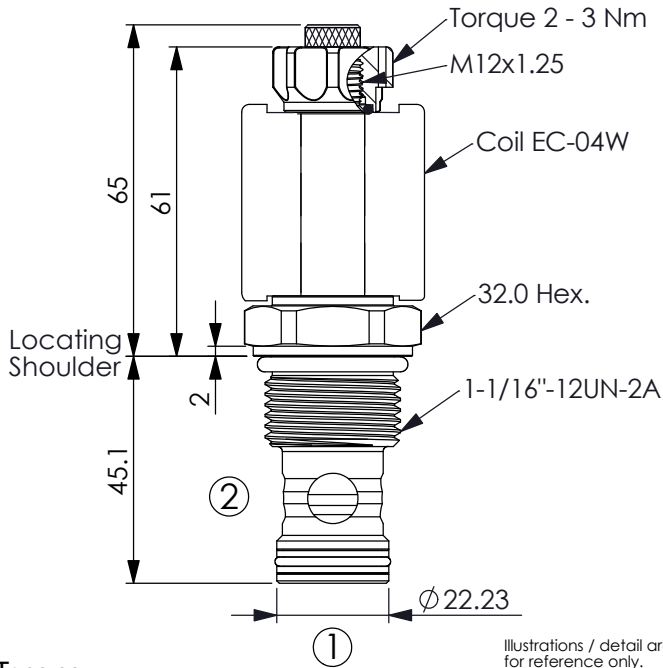

#### TECHNICAL DATA

Max. Operating pressure:	350 bar
Rated flow:	150 l/min
Cavity-Tooling:	12W-2
Installation torque:	54 - 66 Nm
Weight:	0.22 (Z=N) 0.23 (Z=M) kg

UNIT:mm

Illustrations / detail are for reference only. Data subject to change.

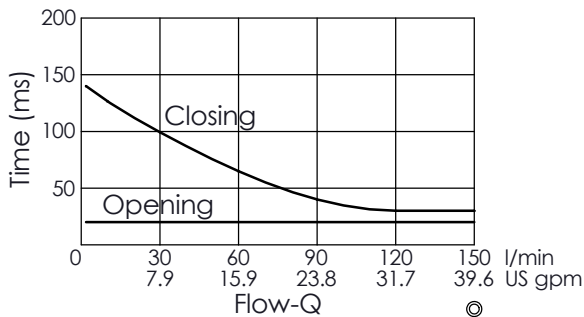
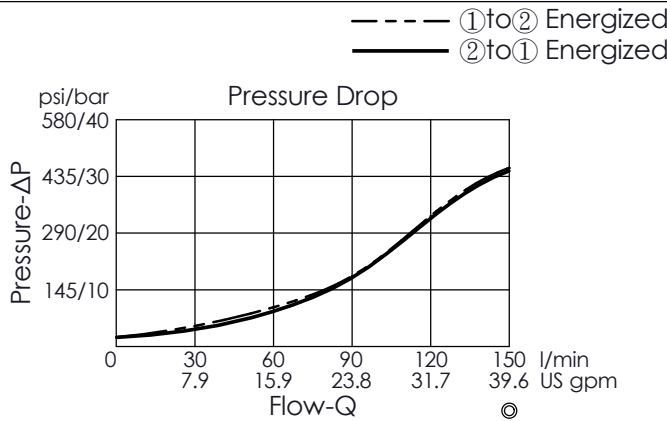

The performance curve or data is only for reference, as customers' using condition, pressure, flow, hydraulic fluid viscosity, cleanliness, temperature and so on are different, the curve or data will be different.

Internal Leakage Approximately:  
0.15 cc/minute  
(3 drops/minute) max. at 350 bar

Hydraulic Fluid Viscosity · Cleanliness · Temperature Level:  
Please refer WINNER technical information.  
( T.101.101.E HYDRAULIC FLUID (A) VISCOSITY )  
( T.101.102.E HYDRAULIC FLUID (B) CLEANLINESS )  
( T.101.103.E HYDRAULIC FLUID (C) TEMPERATURE )

Minimum Voltage Required:  
90 % of nominal

Coils must be ordered separately

Mounting Position: unrestricted

X	STRUCTURE	
2A	2 Ports · 20 Watt. Coil Ø 12.7 mm tube	

Z	OPTIONS	
N	Non-adjustable	
M	Screw-out Knob Style	

Y	OPERATION	
31	Normally-Closed Double Lock	