

Ordering Code: **EP-17E-X-Y-Z-85**

This design allows faster response times with very small flow or even virtually zero flow.

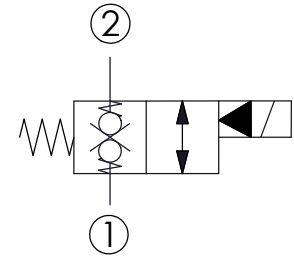
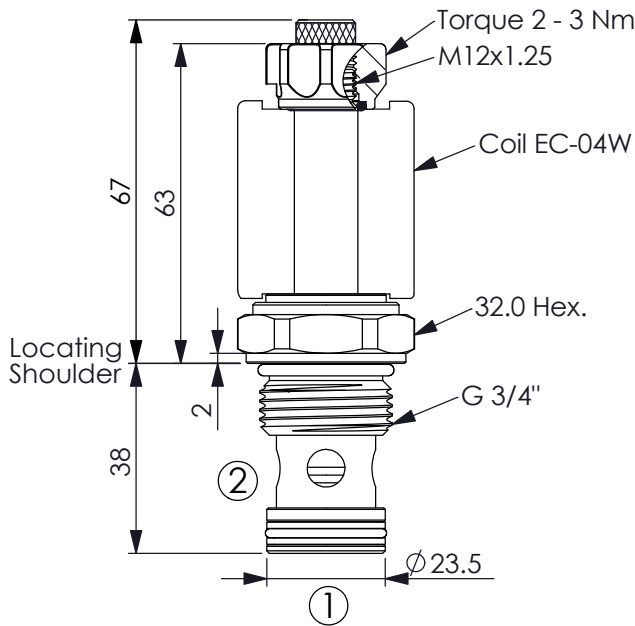

#### TECHNICAL DATA

Max. Operating pressure:	350	bar
Rated flow:	70	l/min
Cavity-Tooling:	17E-2	
Installation torque:	54 - 66	Nm
Weight:	0.22	kg

UNIT:mm

Illustrations / detail are for reference only. Data subject to change.

Internal Leakage Approximately:  
0.15 cc/minute  
(3 drops/minute) max. at 350 bar

Hydraulic Fluid Viscosity · Cleanliness · Temperature Level:  
Please refer WINNER technical information.  
( T.101.101.E HYDRAULIC FLUID (A) VISCOSITY )  
( T.101.102.E HYDRAULIC FLUID (B) CLEANLINESS )  
( T.101.103.E HYDRAULIC FLUID (C) TEMPERATURE )

Minimum Voltage Required:  
90 % of nominal

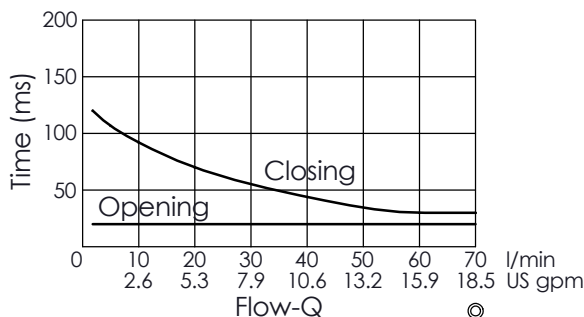
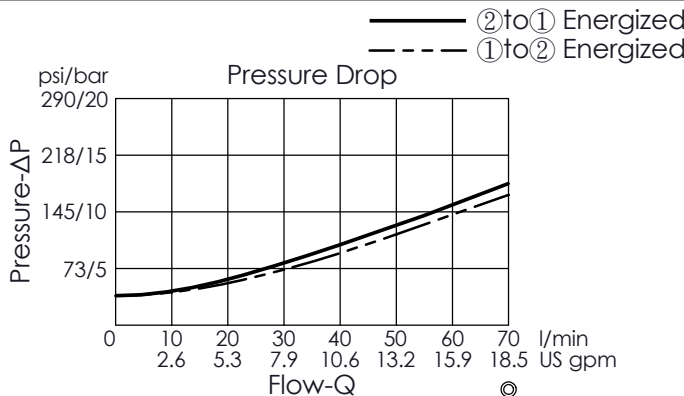

Coils must be ordered separately

Mounting Position: unrestricted

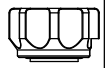

The performance curve or data is only for reference, as customers' using condition, pressure, flow, hydraulic fluid viscosity, cleanliness, temperature and so on are different, the curve or data will be different.

X	STRUCTURE
2A	2 Ports · 20 Watt. Coil ∅ 12.7 mm tube

Z	OPTIONS
N	Non-adjustable 
M	Screw-out Knob Style 

Y	OPERATION
31	Normally-Closed Double Lock