

Ordering Code: **EP-13A-X-Y-Z-05**

※ If you need the type with extra spring (quickly closed), please select EP-13A-2A-31-Z-85

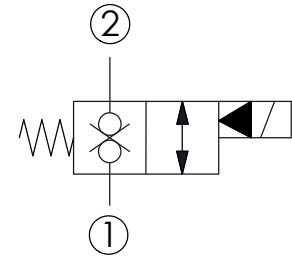
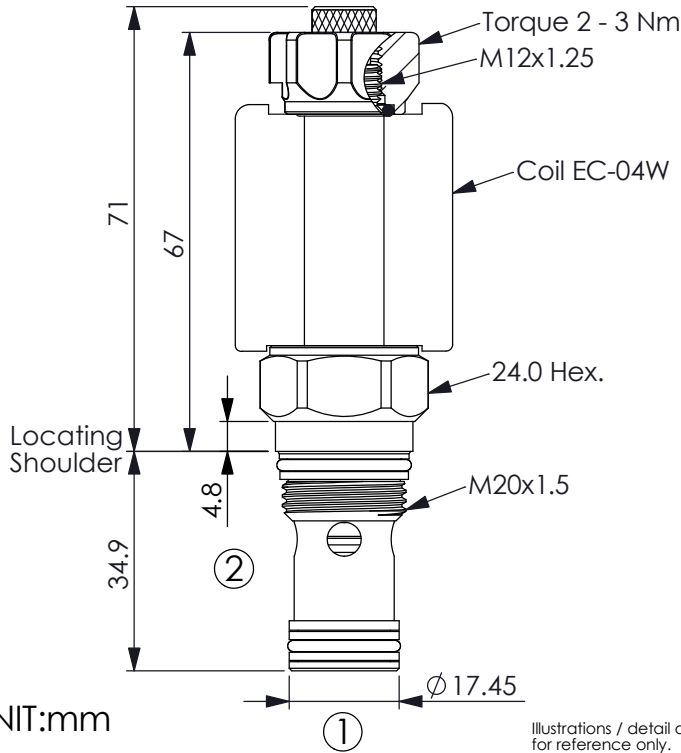

TECHNICAL DATA

Max. Operating pressure:	350	bar
Rated flow:	40	l/min
Cavity-Tooling:	13A-2	
Installation torque:	39 - 51	Nm
Weight:	0.144 (Z=M)	kg

Internal Leakage Approximately:
0.15 cc/minute
(3 drops/minute) max. at 350 bar

Hydraulic Fluid Viscosity · Cleanliness · Temperature Level:
Please refer WINNER technical information.
(T.101.101.E HYDRAULIC FLUID (A) VISCOSITY)
(T.101.102.E HYDRAULIC FLUID (B) CLEANLINESS)
(T.101.103.E HYDRAULIC FLUID (C) TEMPERATURE)

Minimum Voltage Required:
90 % of nominal

Coils must be ordered separately

Mounting Position: unrestricted

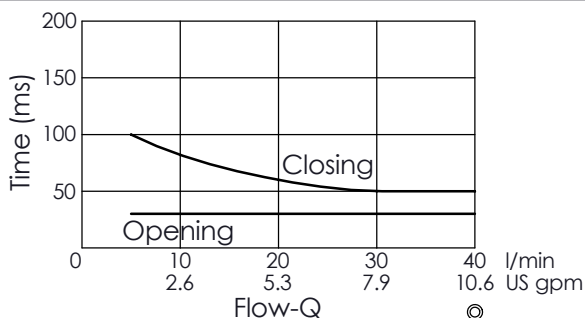
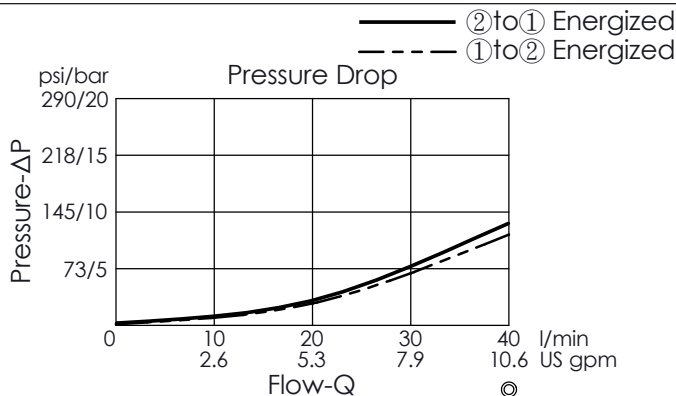

The performance curve or data is only for reference, as customers' using condition, pressure, flow, hydraulic fluid viscosity, cleanliness, temperature and so on are different, the curve or data will be different.

X	STRUCTURE
2A	2 Ports · 20 Watt. Coil ∅ 12.7 mm tube

Y	OPERATION
31	Normally-Closed Double Lock

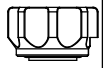
Z	OPTIONS
N	Non-adjustable 
M	Screw-out Knob Style 