

SOLENOID OPERATED VALVE (Direct-Acting) (Spool 2-Way Normally-Close)

Ordering Code: **ES-08W-X-Y-Z-04**

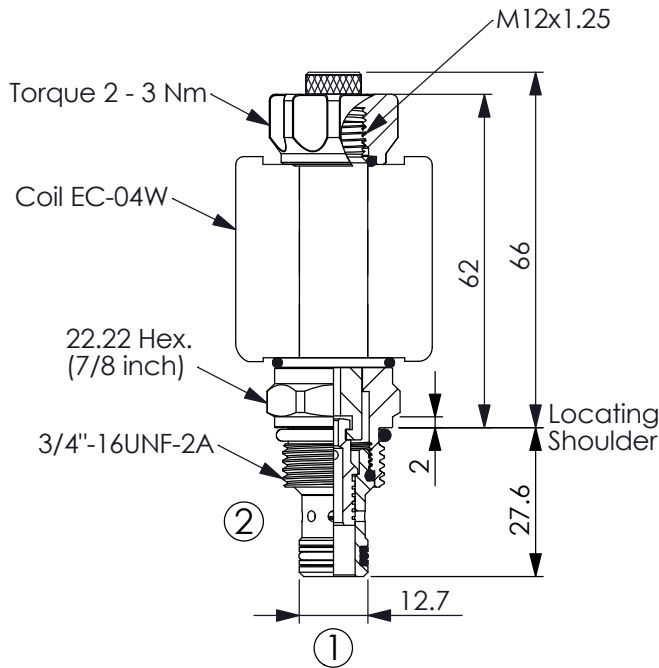

UNIT:mm

Illustrations / detail are for reference only. Data subject to change.

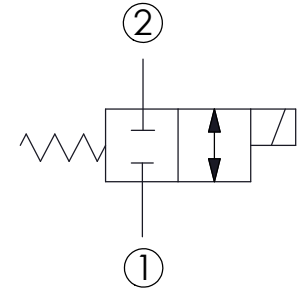

TECHNICAL DATA

Max.Operating pressure: 350 bar
(Refer To Performance Chart)

Rated flow: 15 l/min
(Refer To Performance Chart)

Cavity-Tooling: 08W-2

Installation torque: 39 - 51 Nm

Weight: 0.10 (Z=M) kg

Response time depending on pressure and flow	ON	30 - 60 ms
	OFF	20 - 40 ms

Hydraulic Fluid Viscosity · Cleanliness · Temperature Level:
Please refer WINNER technical information.
(T.101.101.E HYDRAULIC FLUID (A) VISCOSITY)
(T.101.102.E HYDRAULIC FLUID (B) CLEANLINESS)
(T.101.103.E HYDRAULIC FLUID (C) TEMPERATURE)

Minimum Voltage Required:
90 % of nominal

Coils must be ordered separately

Mounting Position: unrestricted

Performance Chart

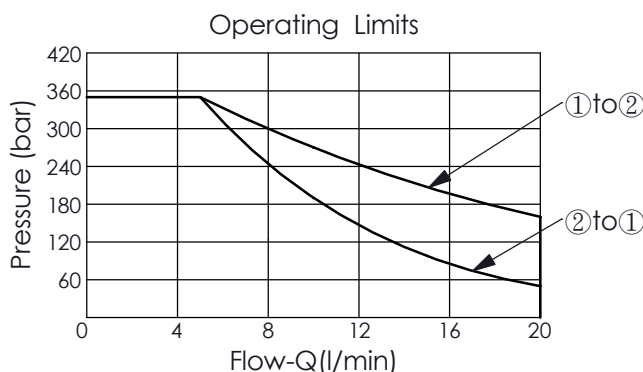
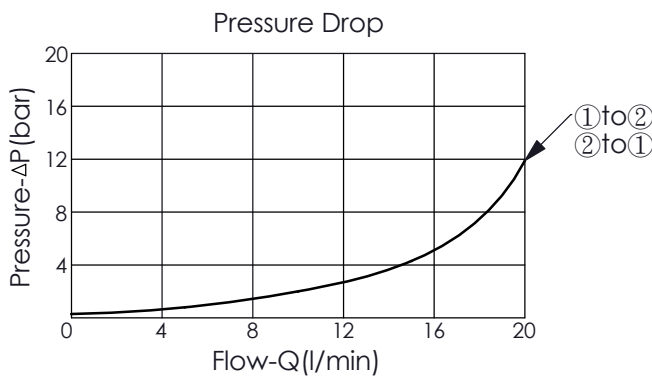

The performance curve or data is only for reference, as customers' using condition, pressure, flow, hydraulic fluid viscosity, cleanliness, temperature and so on are different, the curve or data will be different.

X	STRUCTURE	
2A	2 Ports · 20 Watt. Coil ∅ 12.7 mm tube	
Y	OPERATION	
14	Spool 2-Way, 2-Position Normally-Close	
Z	OPTIONS	
N	Non-adjustable	
M	Screw-out Knob Style	