

Y	OPERATION
13	Spool 3-Way, 2 Position

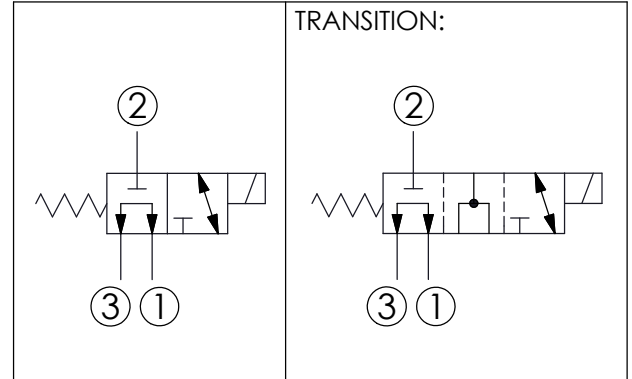

TECHNICAL DATA	
Max. Operating pressure:	350 bar (Refer To Performance Chart)
Rated flow:	10 l/min (Refer To Performance Chart)
Cavity-Tooling:	08W-3
Installation torque:	39 - 51 Nm
Weight:	0.11 (Z=N) 0.13 (Z=M) kg

Response time depending on pressure and flow	ON	30 - 60 ms
	OFF	20 - 40 ms

Hydraulic Fluid Viscosity · Cleanliness · Temperature Level:
Please refer WINNER technical information.
(T.101.101.E HYDRAULIC FLUID (A) VISCOSITY)
(T.101.102.E HYDRAULIC FLUID (B) CLEANLINESS)
(T.101.103.E HYDRAULIC FLUID (C) TEMPERATURE)

Minimum Voltage Required:
90 % of nominal

Coils must be ordered separately

Mounting Position: unrestricted

X	STRUCTURE
3A	3 Ports · 20 Watt. Coil ∅ 12.7 mm tube

Z	OPTIONS
N	Non-adjustable
M	Screw-out Knob Style