

Ordering Code: **ES-08W-X-Y-Z-04-H**

Note:
The direction of coil has to be installed properly, otherwise the efficiency of magnetic force will be insufficient.

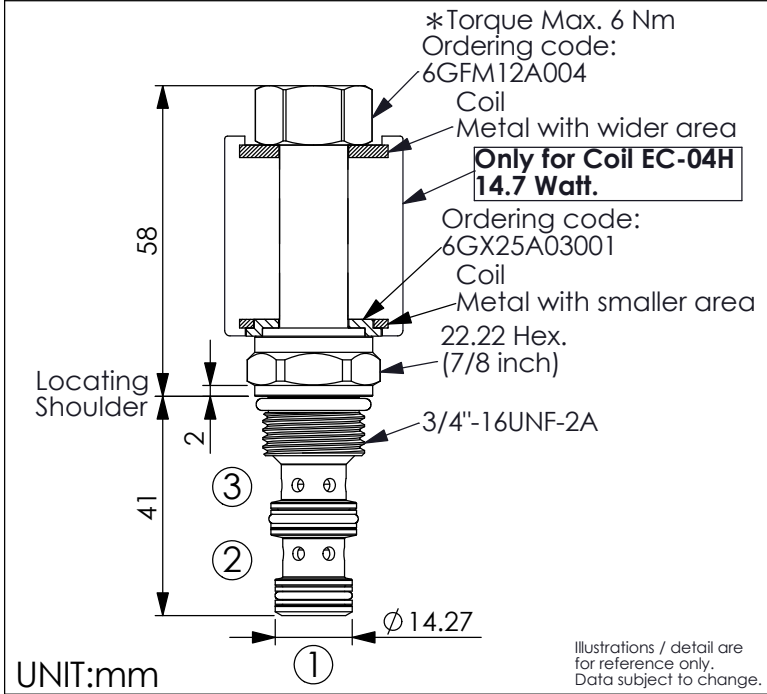

Performance Chart

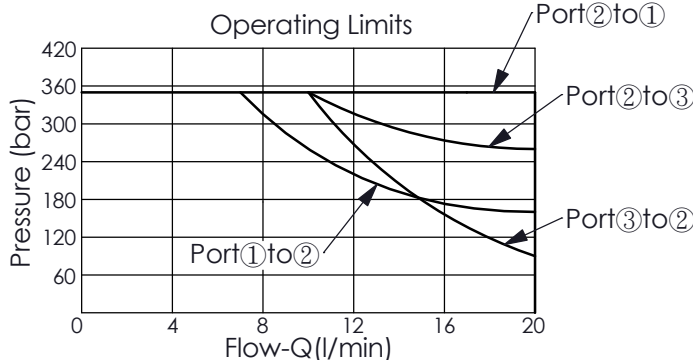
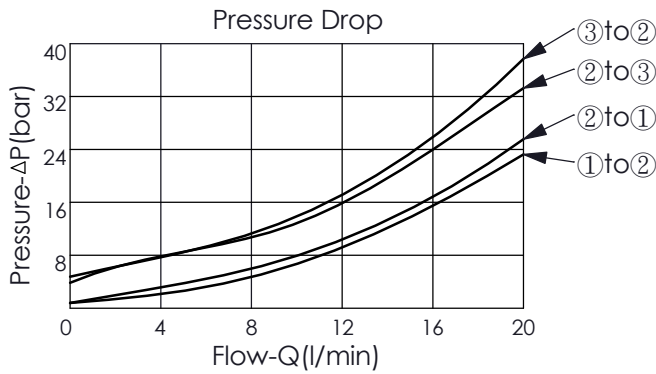

The performance curve or data is only for reference, as customers' using condition, pressure, flow, hydraulic fluid viscosity, cleanliness, temperature and so on are different, the curve or data will be different.

Y	OPERATION
15	Spool 3-Way, 2-Position

TRANSITION:

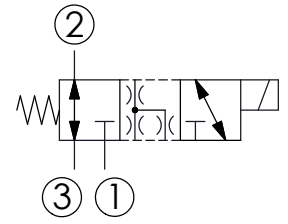
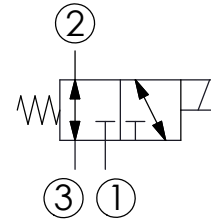

TECHNICAL DATA

Max. Operating pressure:	350 bar
(Refer To Performance Chart)	
Rated flow:	15 l/min
(Refer To Performance Chart)	
Cavity-Tooling:	08W-3
Installation torque:	39 - 51 Nm
Weight:	0.13 kg

Internal Leakage Approximately:
80 cc/minute
max. at 210 bar

Response time depending on pressure and flow	ON	30 - 60 ms
	OFF	20 - 40 ms

Hydraulic Fluid Viscosity · Cleanliness · Temperature Level:
Please refer WINNER technical information.
(T.101.101.E HYDRAULIC FLUID (A) VISCOSITY)
(T.101.102.E HYDRAULIC FLUID (B) CLEANLINESS)
(T.101.103.E HYDRAULIC FLUID (C) TEMPERATURE)

Minimum Voltage Required:
90 % of nominal

Coils must be ordered separately

Mounting Position: unrestricted

X	STRUCTURE
3A	3 Ports · 14.7 Watt. Coil Ø 12.7 mm, 45mm length tube

Z	OPTIONS
N	Non-adjustable 