

## SOLENOID OPERATED VALVE (Direct-Acting) (Spool 4-Way 2-Position)

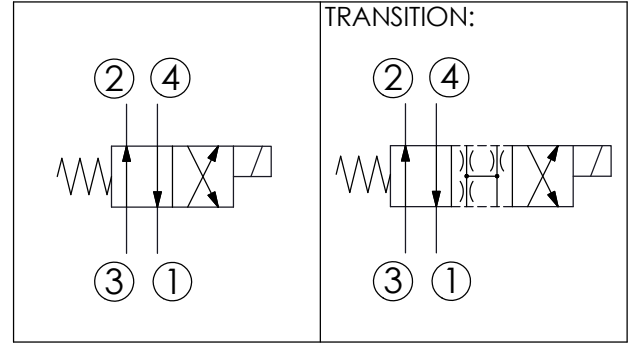
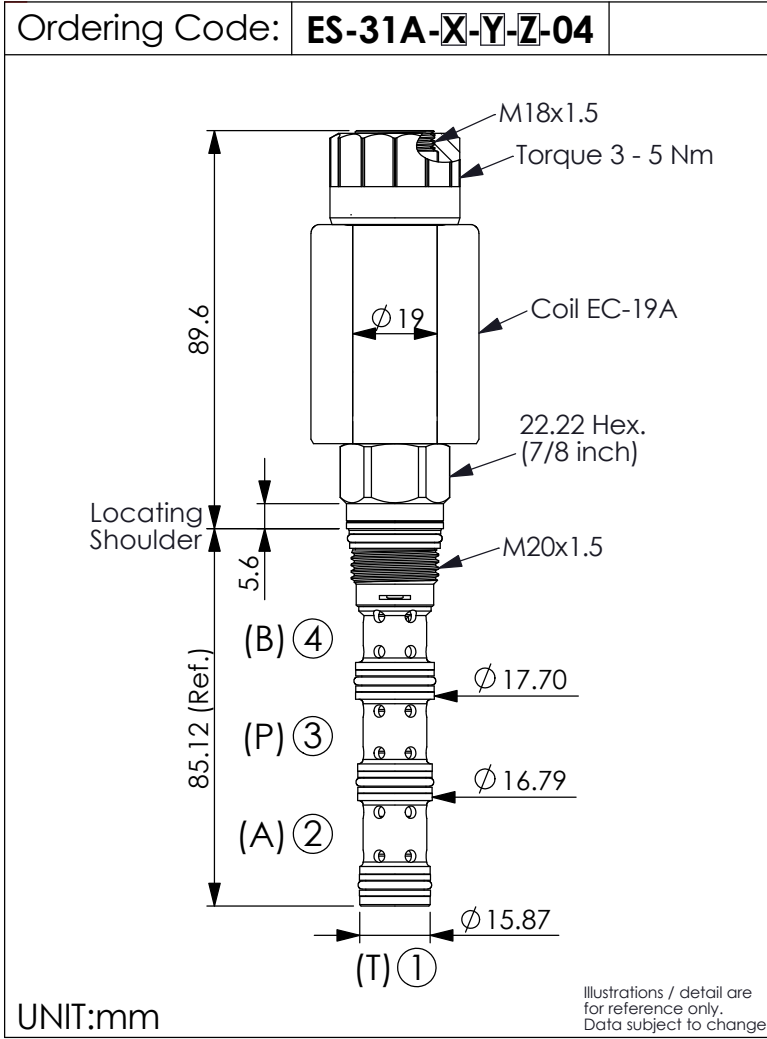

TECHNICAL DATA	
Rated pressure:	350 bar (Refer To Performance Chart)
Rated flow:	40 l/min (Refer To Performance Chart)
Cavity-Tooling:	31A-4
Installation torque:	40 - 50 Nm
Weight:	0.296 (Z=N) kg

Response time depending on pressure and flow	40 - 60 ms
----------------------------------------------	------------

Hydraulic Fluid Viscosity · Cleanliness · Temperature Level:  
Please refer WINNER technical information.  
( T.101.101.E HYDRAULIC FLUID (A) VISCOSITY )  
( T.101.102.E HYDRAULIC FLUID (B) CLEANLINESS )  
( T.101.103.E HYDRAULIC FLUID (C) TEMPERATURE )

Minimum Voltage Required:	90 % of nominal
Coils must be ordered separately	
Mounting Position:	unrestricted

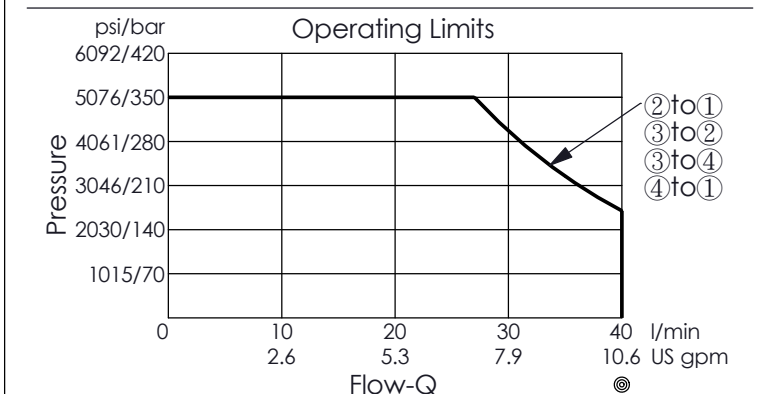
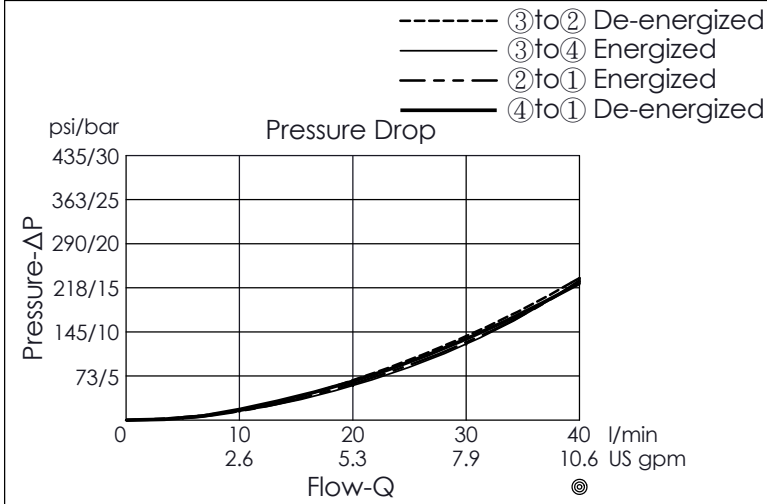

The performance curve or data is only for reference, as customers' using condition, pressure, flow, hydraulic fluid viscosity, cleanliness, temperature and so on are different, the curve or data will be different.

<b>X</b>	<b>STRUCTURE</b>
<b>4D</b>	4 Ports · 22 Watt. Coil Ø 19 mm tube

<b>Y</b>	<b>OPERATION</b>
<b>10</b>	Spool 4-Way, 2-Position

<b>Z</b>	<b>OPTIONS</b>
<b>N</b>	Non-adjustable
<b>P</b>	Push Style Manual Override