

Ordering Code: **ES-08W-X-Y-Z-05**

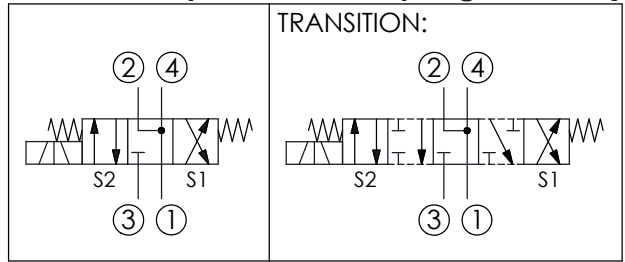
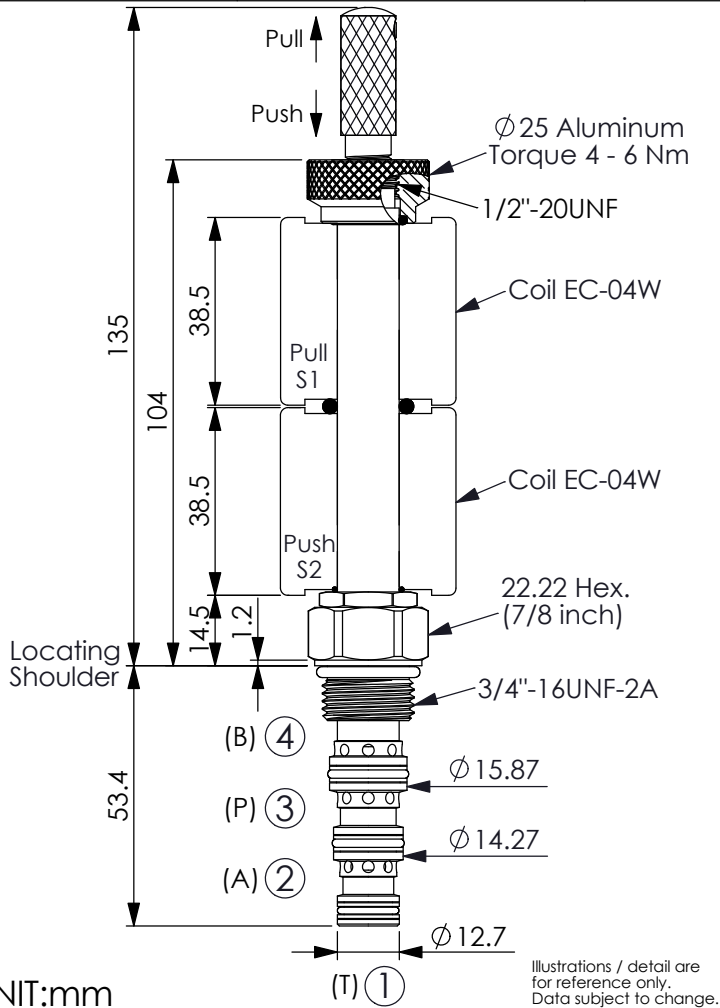

TECHNICAL DATA

Rated pressure:	350 bar
(Refer To Performance Chart)	
Max. pressure at Port ①:	210 bar
Rated flow:	15 l/min
(Refer To Performance Chart)	
Cavity-Tooling:	08W-4
Installation torque:	39 - 51 Nm
Weight:	0.173 (Z=N) kg

Response time depending on pressure and flow	ON	30 - 60 ms
	OFF	20 - 40 ms

Hydraulic Fluid Viscosity · Cleanliness · Temperature Level:
Please refer WINNER technical information.
(T.101.101.E HYDRAULIC FLUID (A) VISCOSITY)
(T.101.102.E HYDRAULIC FLUID (B) CLEANLINESS)
(T.101.103.E HYDRAULIC FLUID (C) TEMPERATURE)

Minimum Voltage Required:
90 % of nominal

Coils must be ordered separately

Mounting Position: unrestricted

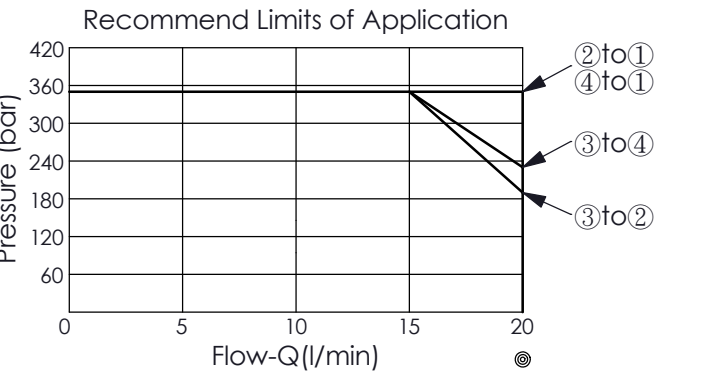
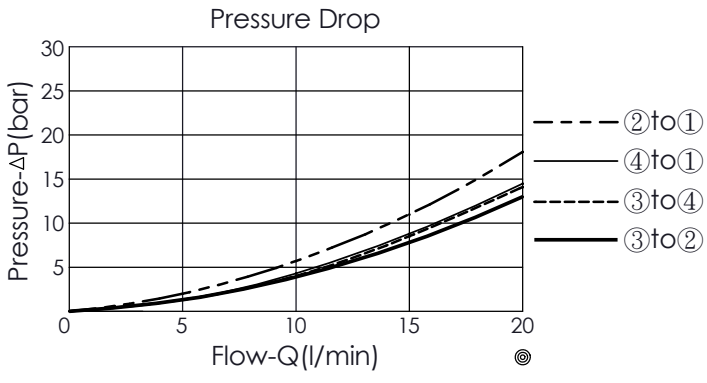

The performance curve or data is only for reference, as customers' using condition, pressure, flow, hydraulic fluid viscosity, cleanliness, temperature and so on are different, the curve or data will be different.

X	STRUCTURE
4A	4 Ports · 20 Watt. Coil ∅ 12.7 mm tube

Y	OPERATION
24	Spool 4-Ways, 3-Positions, A and B to T Centre

Z	OPTIONS
N	Non-adjustable
D	Pull or Push Style Manual Override