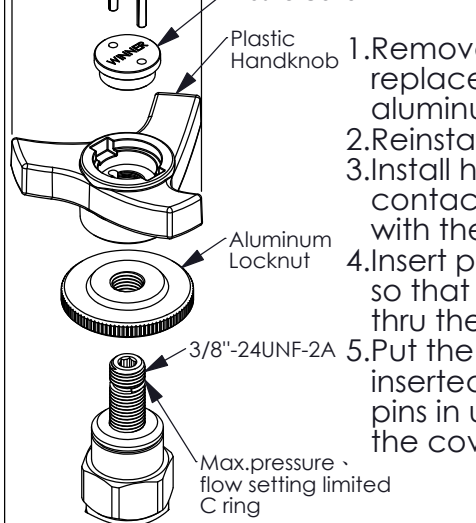
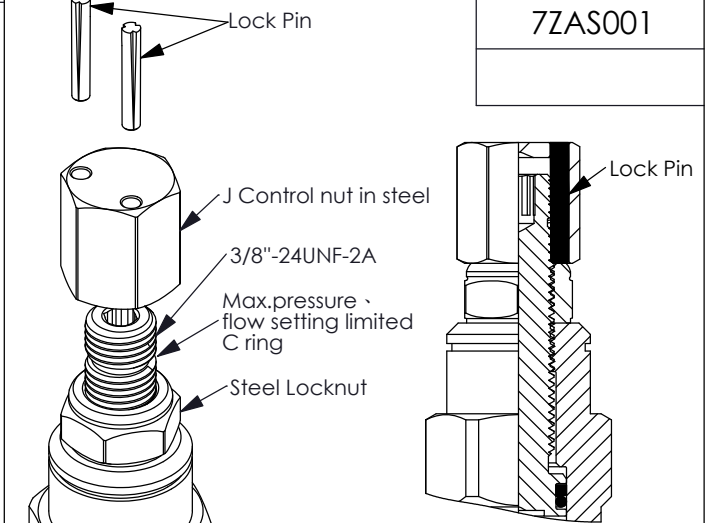

CARTRIDGE CONTROL OPTIONS

T	Three-winged Handknob Kit	J	Control Kit, Max. Setting Limiter
<p>This control kit can be used on most of Winner's cartridges. The installation of this kit is intended to be permanent. Once assembled to the cartridge, it cannot be easily readjusted or disassembled.</p>		<p>The J Control kits use for the setting of the cartridges. They can be adjusted within their specified range not to exceed the new permanent maximum setting. The J Control kits use for the setting of the cartridges. After leakproof hex. socket screw is set to the maximum allowance pressure or flow, first to take off "the maximum setting limitation C spring" and then turn the J Control kits until touching lock nut. Finally, insert the pins and drive pins in until flush in J Control kits. The installation of this kit is permanent. It cannot be readjusted or disassembled.</p>	
<p>Weight: 0.049 kg</p>		<p>Weight: 0.018 kg</p>	
			
<p>Order Code 7ZAT001</p> <ol style="list-style-type: none"> 1. Remove stop ring and replace lock nut with aluminum lock knob. 2. Reinstall stop ring. 3. Install handknob until contact is made with the stop ring. 4. Insert pins in the cover so that they project thru the cover. 5. Put the cover on with inserted pins and drive pins in until flush with the cover. <p>*Note: The three-winged handknob kit cannot reassemble after completing. Please tighten screw thoroughly and make sure the adjustment range is enough. If you have any question, please contact Winner's sale department.</p> <p>The appearance and the dimension are only for reference.</p> <p>UNIT:mm</p>		<p>Order Code 7ZAS001</p> <p>The appearance and the dimension are only for reference.</p> <p>UNIT:mm</p>	